

# Installation guide

## NCA Series 400 single blade leakage rated fire damper c/w plate frame

### Prior to installation

- Thermal links/probes in particular are vulnerable to damage, take extreme care if storing smaller dampers within larger dampers. Damaged links/probes must be replaced.
- If damper is to be stored on site, ensure it is stored in a clean and dry environment.
- Immediately prior to fitment, remove all packaging from the unit. Take particular care inspecting the inside of the unit for any packing materials which may disrupt damper operation.
- Perform a visual check of the damper to ensure it is free from damage.

### Installation

- Fire damper installation should only be carried out by competent persons.
- Appropriate PPE should be used throughout the installation.
- Provision for access to both sides of the damper (inside the duct) must be made.
- Any cabling should be tied back so as not to be in contact with the duct.
- Breakaway joints should be used where ductwork connects to a damper spigot, for example through the use of aluminium rivets.
- Case sealing rings should be lubricated to ease ductwork connection, for example with a sprayed washing-up liquid solution or similar.

- There should be a minimum of 200mm of supporting construction between fire dampers installed in separate ducts.
- There should be a minimum of 75mm of supporting construction between the fire damper and any adjacent construction element, e.g. a wall or ceiling.  
*Where a damper is fitted such that the actuator shall be next to a wall, this should be increased to 200mm to provide adequate clearance.*
- A decrease of the gap (area) between the damper and supporting construction is permitted (as per EXAP report, EN 15882-2:2015, clause X.46).

**Recommended spares:** S400H - Thermal link in correct temperature rating  
68°C (red bulb in link) or 93°C (green bulb in link)

S400A - Thermal probe tripping element - 'Belimo ZBAT72'

### Installation S400-2VP Drywall partition installation



Installation classified to (in accordance with BS EN 13501-3):  
**E 120 (ve i-→) S**  
120 minute rated reduced leakage vertical installation  
Air permitted to flow in either direction through damper

#### Installation procedure

- Construct drywall partition steel frame incorporating a square aperture for the damper:
  - 94mm larger than damper nominal size (if using 15mm thick plasterboard)
  - 84mm larger than damper nominal size (if using 12.5mm thick plasterboard)
- Fill wall cavity with mineral wool (optional, see note below) and fix two layers of plasterboard to both sides of partition and inside of aperture (lined aperture should be 34mm larger than damper nominal size).
- Centralise damper spigot within aperture.
- Screw damper to partition using all pre-cut 5mm holes in plate frame, ensure all screws gain a positive fix.
- S400A only - Fit thermal probe to top half of ductwork and connect actuator to an appropriate power supply.

#### Material specifications

**Wall:** Minimum 'EI 60 group A' spec as per EN 1363-1:2020  
Minimum thickness 100mm  
**Fixing screws:** Minimum spec 4.2mm x 65mm drywall screws

#### Notes

- No backfilling, sealing or pattress frame is required.
- The blade axis can be on any angle.
- The steel aperture frame must be joined to vertical frame members which are themselves fixed to the supporting construction.
- Mineral wool infill is optional (as per EN 1366-2:2015, clause 13.7).

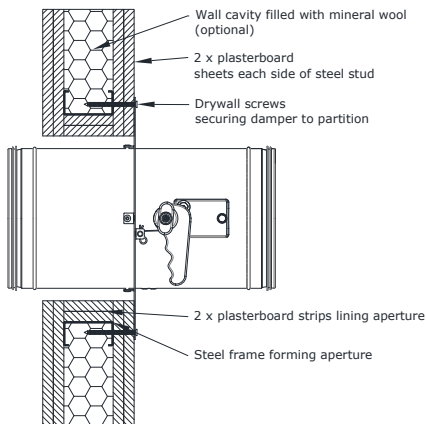

### Installation S400-2VM Masonry wall installation



Installation classified to (in accordance with BS EN 13501-3):  
**E 120 (ve i-→) S**  
120 minute rated reduced leakage vertical installation  
Air permitted to flow in either direction through damper

#### Installation procedure

- Construct wall incorporating a square or circular aperture for the damper 34mm larger than damper nominal size.
- Open the pre-cut 5mm diameter fixing holes in the plate frame out to 8mm.
- Centralise damper spigot within aperture.
- Screw damper to wall using all 8mm holes in plate frame, ensure all screws gain a positive fix.
- S400A only - Fit thermal probe to top half of ductwork and connect actuator to an appropriate power supply.

#### Material specifications

**Wall:** Rigid standard wall as per EN 1363-1  
Minimum thickness 100mm  
**Fixing screws:** Minimum spec 6mm x 60mm masonry screws

#### Notes

- No backfilling, sealing or pattress frame is required.
- The blade axis can be on any angle.

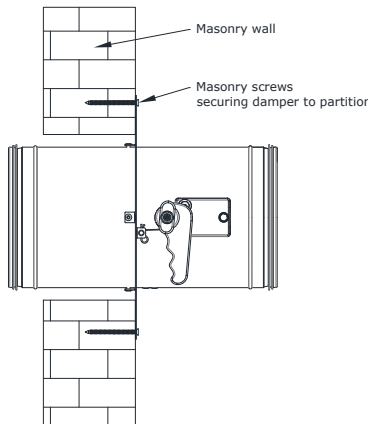

### Installation S400-2HC Concrete floor installation



Installation classified to (in accordance with BS EN 13501-3):  
**E 120 (ho i-→) S**  
120 minute rated reduced leakage horizontal installation  
Air permitted to flow in either direction through damper

#### Installation procedure

- Construct floor slab incorporating a square or circular aperture for the damper 34mm larger than damper nominal size.
- Open the pre-cut 5mm diameter fixing holes in the plate frame out to 8mm.
- Centralise damper spigot within aperture.
- Screw damper to slab using all 8mm holes in plate frame, ensure all screws gain a positive fix.
- S400A only - Fit thermal probe to ductwork and connect actuator to an appropriate power supply.

#### Material specifications

**Floor:** Concrete slab (aerated or normal)  
Minimum thickness 150mm  
Minimum density 500kg/m<sup>3</sup>  
**Fixing screws:** Minimum spec 6mm x 60mm masonry screws.

#### Notes

- No backfilling, sealing or pattress frame is required.
- The damper must sit on top of the floor, not be hung from below.

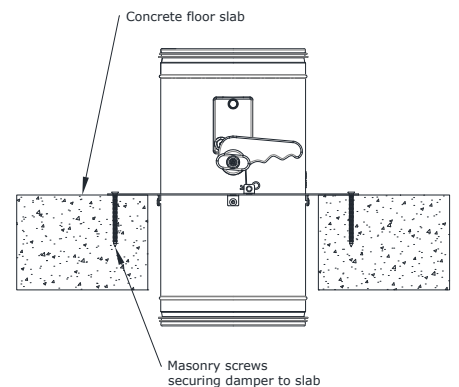

### IMPORTANT NOTE

It is a legal requirement that fire dampers are installed in the way instructed by the manufacturer.  
Any other installation is untested and therefore illegal.

Responsibility for ensuring correct installation lies with all parties in the supply chain.

Installation declaration overleaf →

## Fire damper installation declaration

Installation record, check-list and sign-off

<b>Damper type:</b>	NCA Series 400 single blade leakage rated fire damper c/w plate frame
<b>Variants:</b> <i>Delete as appropriate</i>	S400H (hand operated) S400A (motorised)
<b>Thermal probe rated temperature:</b> <i>Delete as appropriate</i>	S400H - 68°C (red bulb in link) or 93°C (green bulb in link) S400A - 72°C
<b>Damper reference (if applicable):</b>	
<b>Damper location (within site):</b>	
<b>Installation type used (see overleaf):</b>	
<b>Installation address:</b>	

<b>Installation company:</b>	
<b>Installation company contact telephone number:</b>	
<b>Installation company contact email address:</b>	
<b>Installation company address:</b>	

No.	Question	Notes	Yes/No
1	Is the damper correct for the installation?	<i>Are S400 fire dampers c/w plate frame what the installation requires?</i>	
2	Is the damper installed correctly?	<i>Has the damper been installed in accordance with the appropriate method shown overleaf?</i>	
3	Is the penetration solely used by the damper?	<i>Other services running through the same penetration is a violation of the installation method.</i>	
4	Is access sufficient?	<i>Can someone access the inside of the duct and damper safely to perform ongoing inspections and maintenance?</i>	
5	Is the damper in good working condition?	<i>Check specifically for cleanliness, damage and the presence of foreign objects which might obstruct the damper's operation.</i>	
6	Has a successful cycle test been carried out?	<i>Has the damper been cycle tested (on power if motorised) and has the blade itself been observed to open and close correctly?</i>	
7	Is the actuator driving the blades correctly? S400A only	<i>S400 fire dampers must only be used in a power open, fail closed setup.</i>	
8	Do you have any concerns about the installation?	<i>Is there anything that does not look correct, do you have any doubts etc.?</i>	

If any of questions 1 - 7 is answered 'no', or if the answer to question 8 is 'yes', it must be reported to the relevant persons on site and acted upon.

**Print name:**

**Date:**

**Signature:**

Installation guide overleaf →